

High capacity meets superior fire resistance in document storage



Document Protection Cabinets

FIRE-RESISTANT DOCUMENT PROTECTION

High fire risk requires adapted protection

For most companies, important documentation, such as accounting and tax information, contracts, certificates and other sensitive paperwork, is absolutely critical to business continuity. However, the threat of fire is very real for businesses, and can lead to thousands of euros in damage.

Despite this significant risk, many offices lack fire-resistant security solutions that are capable of protecting critical documents from fire while keeping them organised at the same time. Also many fire-resistant document cabinets come with a variety of challenges:

- **Increased risk of fire:** Every year, thousands of businesses are victims of fire. Paper and digital documents are particularly vulnerable to excessive heat, and their loss can have a devastating impact on business continuity.
- **Insufficient testing standards:** Many cabinets offer certified protection against fire but the testing processes to which they are subjected are not always as extensive as needed. For example, internal conditions can deteriorate even after the fire burns out and rapid heating can break through buildings, both of which need to be taken into account to ensure superior resistance.
- **Lack of customisable fittings:** Traditional fire-resistant cabinets provide sufficient shelving but often lack customisable fittings, such as lockable drawers and pullout trays. The result is a security solution that is unable to adapt to very specific business needs.

Chubbsafes
Trusted the world over.

Document Protection Cabinets from Chubb safes is a range of high-capacity storage solutions with a variety of customisable fittings developed to resist fire for up to two hours. The Document Protection Cabinets are tested by UL (Underwriter's Laboratories) according to Standard 72 and are certified for Class 350 for up to 2 hour fire protection. Constructed with the highest quality materials, the Document Protection Cabinets are perfectly suitable for office environments. All models provide functional, ergonomic and modern design which blends nicely into any office configuration.

Superior fire resistance for high-volume document storage



Document Protection Cabinets by Chubb safes is a range of certified cabinets offering the best fire endurance certification label available on the market today: **UL 72 Class 350 2 Hr.** Available in six high-capacity sizes from 160 to 670 litres, Document Protection Cabinets can resist **up to two hours** of

assault by fire, ensuring your documents are fully protected to the highest international standards. A range of customisable internal fittings offers you even more flexibility to organise your documents based on your needs.

Advanced resistance testing for total peace of mind



To ensure you benefit from advanced fire resistance, Document Protection Cabinets are subjected to an extensive fire testing process that consists of placing the cabinet in a furnace, heating it to a temperature of 1000°C or more for two hours, and analysing the internal temperature both during furnace heating and the cooling down process once the furnace burners have been turned off. In addition, UL also includes the following measures in its fire endurance test to ensure superior resistance:

- **Furnace cooling or “soak out”** to replicate the conditions experienced when a fire burns out. After the fire has been extinguished, it is not possible to retrieve your information immediately. Hot rubble continues to heat the cabinet. It is then important that your cabinet is designed to withstand such conditions.
- **Rapid heating** to simulate **explosion testing** at all levels of certification. Rapid heating occurs where fire transits a building quickly so the cabinet can suddenly be subjected to extremely high temperatures. This “explosion” or “shock” test as it is sometimes known, simulates this scenario. Safes not tested in this way may rupture under such conditions leading to loss of contents.

Tried-and-tested durability over the long term

You can rely on the durability of Document Protection Cabinets over the long term thanks to an automatic mechanism, which ensures bolts are in place and able to resist fire whenever the door is closed. The models designed with double doors also include a door interlocking system that prevents the right-hand

door from being closed if the left-hand door is not already secured. For an added layer of reassurance, you can choose to anchor the cabinets to the floor using a standard DuoGuard or ProGuard anchor bolt.

A range of customisable fittings for ultimate flexibility

A wide variety of optional internal fittings ensures you can customise the cabinet to your specific needs. Each cabinet is equipped with a number of standard shelves (ranging from one to four). The underside of each shelf has been developed to allow front loading A4 filing pockets to be suspended below.

The cabinets also include **adjustable pullout frames** for a variety of file sizes and orientations. You can also choose from **lockable cupboards and drawers** for added security, as well as a **pullout tray** for small items or cards.

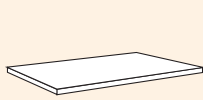

Shelf

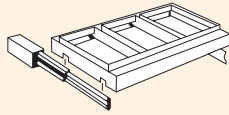

Pull-Out Filing Frame

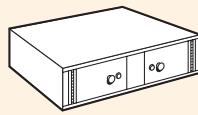

Cupboard

300mm (single version in sizes 1, 2, 4 and 5, side by side version in sizes 3 and 6)

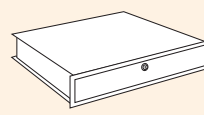

Drawer

80mm

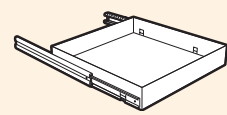

Pull-Out Tray

60mm

At a glance

Ideal for

- Banks and Financial Institutions
- Insurance and Legal Organizations
- Government Departments
- Research & Development and Human Resources Offices
- All customers looking to protect a large volume of high-risk documents

Fittings

- Standard shelves, ranging from 1 to 4
- Pullout filing frames to accommodate a variety of file sizes and orientations
- Lockable cupboards for highly valuable items
- Lockable drawers for added protection
- Pullout trays for small items or cards

Certification

- Fire: UL 72 Class 350 2 Hr for fire protection

Locking

- Choice of single or dual lock, with a wide range of key (Mauer), electronic (Sargent & Greenleaf, LG, Kaba, GSL 1000) and combination (Sargent & Greenleaf) locks available

	Standard Lock	Lock Options
Key Locks	Mauer 71111 A with 150mm key	Mauer 70076 B with 164mm keys (resettable) Mauer 71113 with 164mm keys (non-key retaining)
Electronic Locks	S&G Titan	LG Basic dead bolt 3750 LG 39-E 3750K Kaba 525 Series GSL 1000
Combination Locks	S&G 6642 3 wheel with black dial	S&G 8550 4 wheel anti-manipulation lock



Key Lock



Electronic Lock



Combination Lock

Product Specification

Model	External (mm)			Internal (mm)			Weight (kg)	Volume (litres)
	Height	Width	Depth	Height	Width	Depth		
160	859	759	605	700	600	382	235	160
240	1209	759	605	1050	600	382	315	240
400W	1209	1160	605	1050	1000	382	500	401
320	1559	759	605	1400	600	382	395	321
400T	1909	759	605	1750	600	382	470	401
670	1909	1160	605	1750	1000	382	650	670

6 sizes (from 160 to 670 litres)

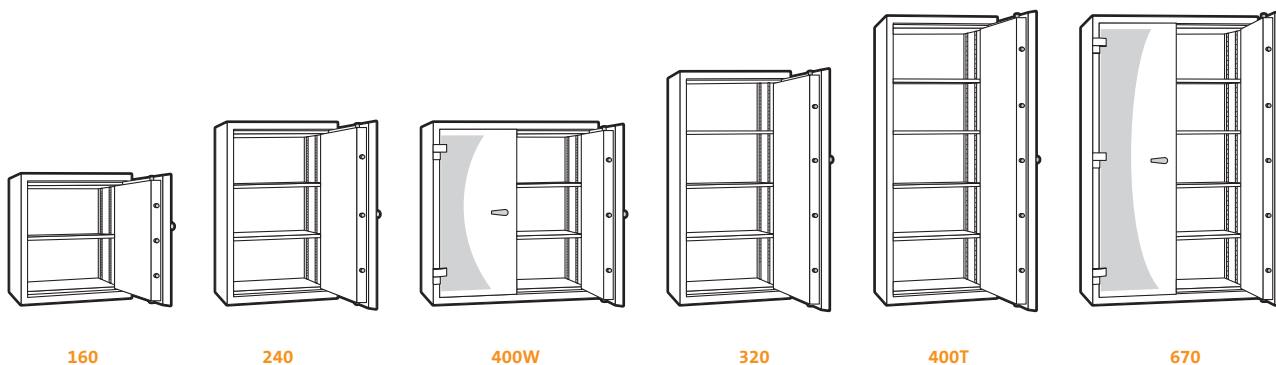

Finish

- **Body & Interior:** RAL 7035 Silver Grey
- **Fascia Panel:** RAL 7016 Anthracite Grey
- **Handle:** Black and Silver
- **Escutcheon:** Black

Authorised dealer

Chubbsafes
Trusted the world over.

www.chubbsafes.com

'Chubb' is owned by Chubb plc and is a registered trademark used under license